

# S50F

## Specifications 1/5

### Incremental Type (Solid shaft,flange)

- Feature: easy to install with flange,optional various output mode,long service life,etc
- Application: textile industry、 packing machinery、 production line,etc,for automation control
- External dimensions: external diameter  $\phi 50\text{mm}$ ,thickness 35.7mm,diameter of shaft 8mm(D type)
- Resolution: up to 23040P/R
- Supply voltage: DC5V; DC8-30V
- Protection: IP50; IP65
- Cable length: 1000mm
- Weight: about 220g

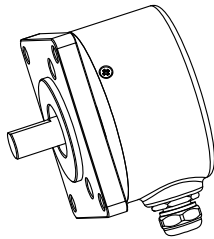

S50F-T

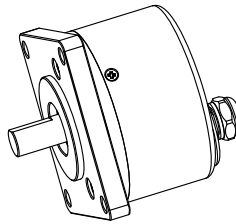

S50F-Q

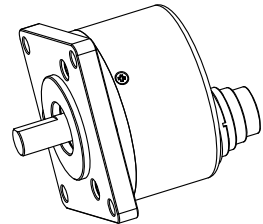

S50F-D

### Model Guide

- Model form (filled required parameters in the box as following)
- Must choose supply voltage: DC5V; DC8-30V
- If need coupling, please purchase additionally (Please refer to accessory at specifications 5/5 )

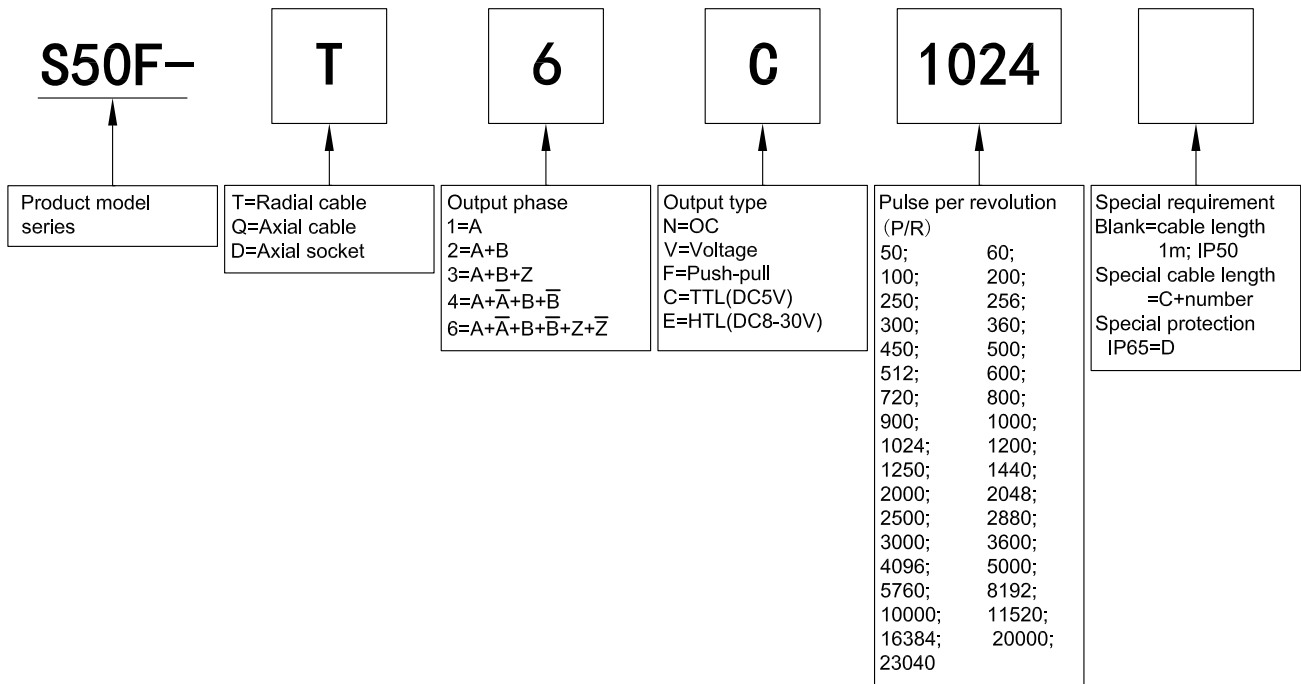

# S50F

## Specifications 2/5

### Output Mode

Output type	Output circuit	Output wave form	Connection
OC		<p><math>a.b.c.d = \frac{T}{4} \pm \frac{T}{8}</math></p> <p>Phase A is ahead of B by <math>\frac{T}{4} \pm \frac{T}{8}</math>, rotate direction CW (View from shaft end, direction is clockwise rotation)</p> <p>CW direction <math>\rightarrow</math></p>	0=GND 1=red=DC5V; DC8-30V 2=black=OV 3=white=A 4=green=B 5=yellow=Z
Push-Pull		<p><math>a.b.c.d = \frac{T}{4} \pm \frac{T}{8}</math></p> <p>Phase A is ahead of B by <math>\frac{T}{4} \pm \frac{T}{8}</math>, rotate direction CW (View from shaft end, direction is clockwise rotation)</p> <p>CW direction <math>\rightarrow</math></p>	
Voltage		<p><math>a.b.c.d = \frac{T}{4} \pm \frac{T}{8}</math></p> <p>Phase A is ahead of B by <math>\frac{T}{4} \pm \frac{T}{8}</math>, rotate direction CW (View from shaft end, direction is clockwise rotation)</p> <p>CW direction <math>\rightarrow</math></p>	
TTL HTL		<p><math>a.b.c.d = \frac{T}{4} \pm \frac{T}{8}</math></p> <p>Phase A is ahead of B by <math>\frac{T}{4} \pm \frac{T}{8}</math>, rotate direction CW (View from shaft end, direction is clockwise rotation)</p> <p>CW direction <math>\rightarrow</math></p>	

### ■ Electrical Characteristics

Parameter Item	Output type	OC		Voltage		Push-pull		TTL		HTL		
Supply voltage		DC+5V±5%; DC8V-30V±5%						DC+5V±5%		DC8-30V±5%		
Consumption current		100mA Max										
Allowable ripple		≤3%rms										
Top response frequency		100KHz						200KHz		300KHz		
Output volume	Output current	Input	≤30mA		Load resistance 2.2K	≤30mA		≤±20mA		≤±50mA		
		Output	—			≤10mA						
	Output voltage	"H"	—		—		≥[(Supply voltage)-2.5V]		≥2.5V		≥V <sub>CC</sub> -3 V <sub>DC</sub>	
		"L"	≤0.4V		≤0.7V(less than 20mA)		≤0.4V(30mA)		≤0.5V		≤1V V <sub>DC</sub>	
	Load voltage	≤DC30V		—		—		—		—		
Rise & Fall time		Less than 2us(cable length: 2m)						Less than 1us (Cable length: 2m)		≤100ns		
Insulation strength		AC500V 60s										
Insulation resistance		10MΩ										
Mark to space ratio		45% to 55%										
Phase shift between A & B		90°±10° ( low speed,frequency ≤1000Hz )										
		90°±20° ( high speed,frequency >1000Hz )										
Origin motion		Low level available		High level available		Low level available		—				
GND		not connect to encoder										

### ■ Mechanical Characteristics

Shaft	∅8mm D type(stainless steel)
Starting torque	Less than $5 \times 10^{-3}$ N·m
Inertia moment	Less than $3 \times 10^{-6}$ kg·m <sup>2</sup>
Shaft load	Radial 40N; Axial 20N
Slew speed	≤5000 rpm; IP65≤3000 rpm
Bearing Life	$1.5 \times 10^9$ revs at rated load(100000hrs at 2500RPM)
Shell	Die cast aluminum
Weight	about 220g

### ■ Environmental Specifications

Environmental temperature	Operating: -20~+80°C(repeatable winding cable: -10°C); Storage: -25~+85°C
Environmental humidity	Operating and storage: 35~85%RH(noncondensing)
Vibration(endure)	Amplitude 0.75mm,5~55Hz,2h for X,Y,Z direction individually
Shock(endure)	490m/s <sup>2</sup> 11ms three times for X,Y,Z direction individually
Protection	IP50; IP65

# S50F Specifications 4/5

Basic Dimensions

- S50F-T

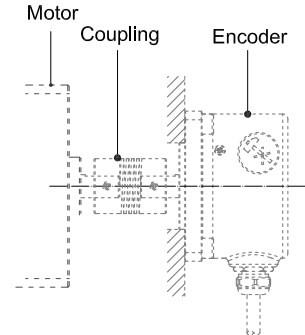
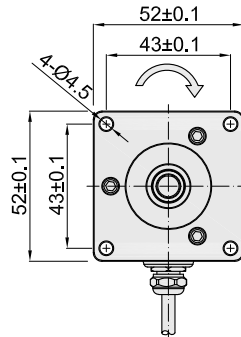
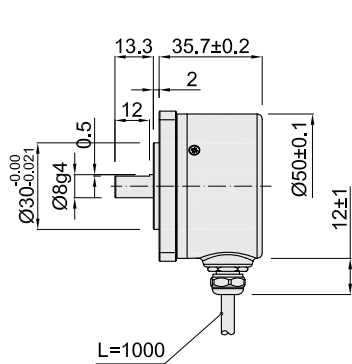

- S50F-Q

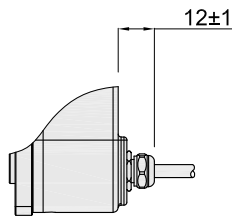

- S50F-D

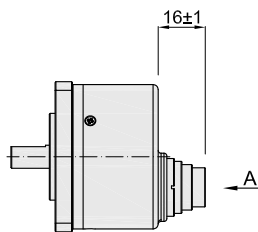

Socket mode: binder(682 series)

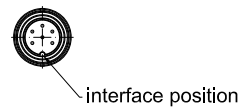
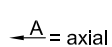

- Pin 1=DC
- 2=OV
- 3=A
- 4=B
- 5=Z
- 6=A
- 7=B
- 8=Z

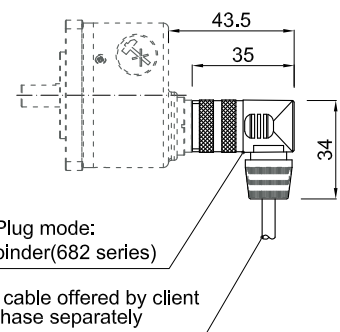

Unit: mm

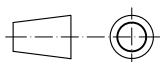

= Rotate direction of signal output shaft

# S50F Specifications 5/5

■ Accessory(Need purchase additionally)

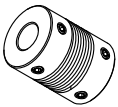
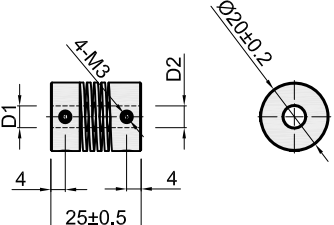
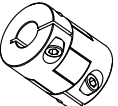
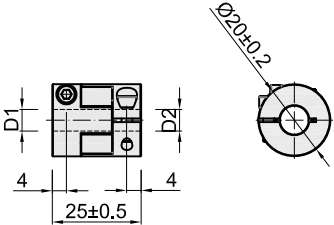
<p>H series spring coupling (general accuracy, or choose M series for higher accuracy) 6H8 No:8700022 8H8 No:8700023 8H10 No:8700007</p> 		Model	D1	D2
		6H8	Ø6 <sup>+0.01</sup> / <sub>+0.03</sub>	Ø8 <sup>+0.01</sup> / <sub>+0.03</sub>
		8H8	Ø8 <sup>+0.01</sup> / <sub>+0.03</sub>	
		8H10		Ø10 <sup>+0.01</sup> / <sub>+0.03</sub>
material: aluminium alloy				
<p>M series oldham coupling 6M8 No:8700038 8M8 No:8700039 8M10 No:8700040</p> 		Model	D1	D2
		6M8	Ø6 <sup>+0.01</sup> / <sub>+0.03</sub>	Ø8 <sup>+0.01</sup> / <sub>+0.03</sub>
		8M8	Ø8 <sup>+0.01</sup> / <sub>+0.03</sub>	
		8M10		Ø10 <sup>+0.01</sup> / <sub>+0.03</sub>
material: aluminium alloy				

■ Assembling requirement

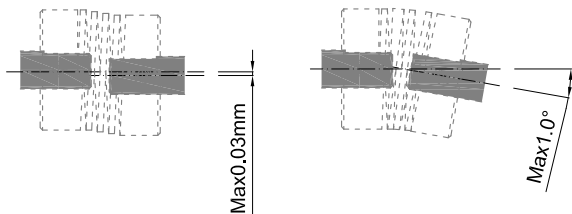

Notice : coaxiality between shaft of encoder and power shaft must be less than 0.03mm, and gradient must be less than 1.0°.

Unit: mm

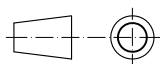

About vibration

Vibration act on encoder always cause wrong pulse , so we should pay attention to working place. More pulse per revolution , narrower groovy spacing of grating , more effect to encoder by vibration, when rev is low or stop , vibration act on shaft or main body would cause grating vibrating , so encoder might make wrong pulse.